

Film packaging of envelopes

One *HUGO BECK* solution for feeding – counting – packaging

For 5 packaging styles



Shrink Packaging

The products are wrapped in a Polyolefin film, which is sealed on 3 sides. By adding heat in the shrink tunnel, the film shrinks down and covers the products tightly.

Tight Packaging

With *HUGO BECK*'s unique solution, envelopes can be wrapped very tightly in CPP or OPP film with a 3-side seal. This kind of packaging qualifies specially for thin stacks and for packs with a tear-open strip.

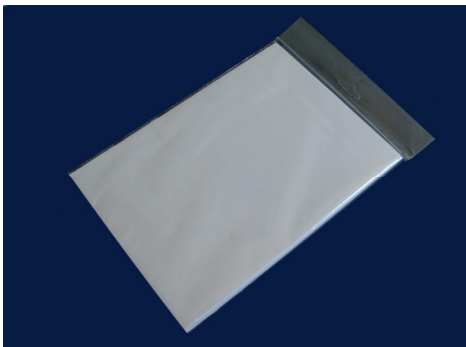

Header Packaging with a Hang Hole

The package is being added a standard or reinforced extension with a hang hole: for the point-of sale presentation on the display.

Packaging with a Reclosable Flap

Multiple opening and closing of the package. Removing of an envelope, the remaining ones stay clean and protected in the package. A solution with an additional benefit for the customer.



Packaging with a Reclosable Flap and a Reinforced Header with Hang Hole the *HUGO BECK* Display Pack

Film packaging of envelopes

e.g. with the
film packaging machine servo X

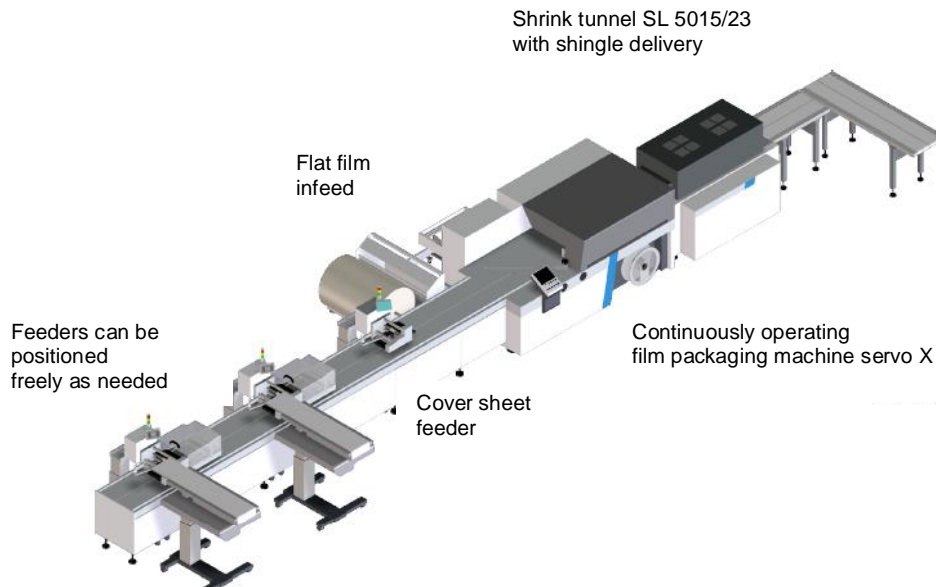

for shrink packaging or
tight packaging

Equipment:

- 2 moveable friction feeders RA 370 with shingled infeed for feeding and counting of envelopes
- 1 friction feeder RA250 for the feeding of cover sheets
- shrink tunnel SL 5015/23 with shingle delivery

Output data:

size DL in stacks of
10, 25, 50 and 100 pcs 70, 38, 22 resp. 11 packs/min.

size C5 in stacks of
5, 10, 25, 50 and 100 pcs 80, 60, 34, 18 resp. 9 packs/min.

size C4 in stacks of
5, 10, 25, 50 and 100 pcs 74, 50, 25, 50 resp. 7 packs/min.